

STRAIGHT JACK SOLDER TYPE

R113.221.000

CABLE .047

Series : MCX

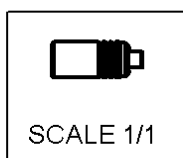
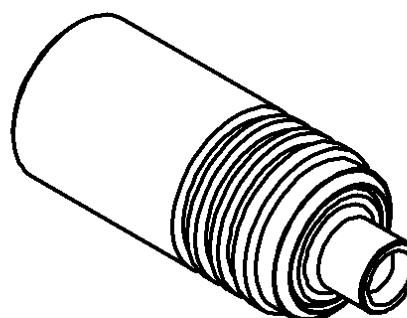
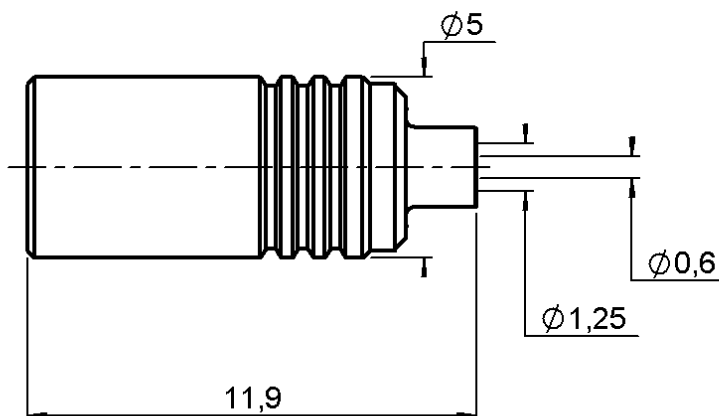

All dimensions are in mm.



COMPONENTS	MATERIALS	PLATINGS (µm)
BODY	BRASS	GOLD 0.2 OVER NICKEL 2
CENTER CONTACT	BERYLLIUM COPPER	GOLD 1.3 OVER NICKEL 2
OUTER CONTACT	-	-
INSULATOR	PTFE	-
GASKET	-	-
OTHERS PARTS	BRASS	GOLD 0.2 OVER NICKEL 2
-	-	-
-	-	-

Issue : 0214 C

In the effort to improve our products, we reserve the right to make changes judged to be necessary.



STRAIGHT JACK SOLDER TYPE

R113.221.000

CABLE .047

Series : MCX

PACKAGING

Standard	Unit	Other
1	-	Contact us

SPECIFICATION

CABLE ASSEMBLY

ELECTRICAL CHARACTERISTICS

Stripping	a	b	c	d	e	f
mm	2.70	0.00	0.00	0.00	2.10	0.00

Impedance		50	Ω
Frequency		0-6	GHz
VSWR	1.10 +	0.040	x F(GHz) Maxi
Insertion loss		0.25	\sqrt{F} (GHz) dB Maxi
RF leakage	- (NA	- F(GHz)) dB mini
Voltage rating		175	Veff Maxi
Dielectric withstanding voltage		500	Veff mini
Insulation resistance		1000	M Ω mini

Assembly instruction :

Recommended cable(s)
.047

Cable retention

- pull off **45** N mini
- torque **NA** N.cm

MECHANICAL CHARACTERISTICS

TOOLING

Center contact retention		
Axial force – Mating end	NA	N mini
Axial force – Opposite end	NA	N mini
Torque	NA	N.cm mini

Part Number	Description	Hexagon
.	.	.
R282.740.020	SOLDERING MOUNTING	

Recommended torque		
Mating	NA	N.cm
Panel nut	NA	N.cm
Clamp nut	NA	N.cm
A/F clamp nut	0.000	mm

OTHERS CHARACTERISTICS

Mating life	500	Cycles mini
Weight	0.945	g

ENVIRONMENTAL

Operating temperature	-55/+115	$^{\circ}$ C
Hermetic seal	NA	Atm.cm3/s
Panel leakage	NA	

Issue : 0214 C

In the effort to improve our products, we reserve the right to make changes judged to be necessary.



STRAIGHT JACK SOLDER TYPE

R113.221.000

CABLE .047

Series : MCX

COMPONENT

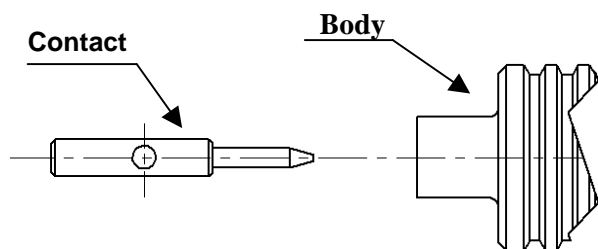

STRIPPING DIMENSIONS

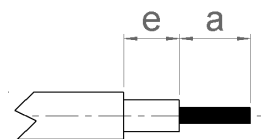

We recommend a thermal preconditioning cable.

1

Cable stripping.

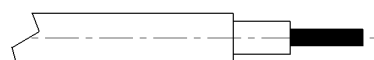

2

Tin centre contact solder pot.
Solder centre contact on cable inner conductor.
Clean solder.



3

Introduce cable into the connector body until contact with the body shoulder.
Place the sub assembly into the assembly jig R282 740 020 (or equivalent).
We advice to connect a female receptable to the connector prior to solder the body in order to respect right centre contact position.
Tighten the sub assembly.
Solder body on the cable.
Let the assembly cool down before removing it from the jig.
Clean solder.

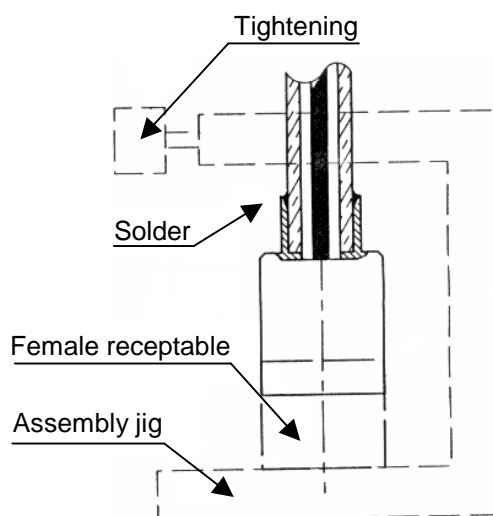

Issue : 0214 C

In the effort to improve our products, we reserve the right to make changes judged to be necessary.

